

Desktop/Cartesian Type

Robot

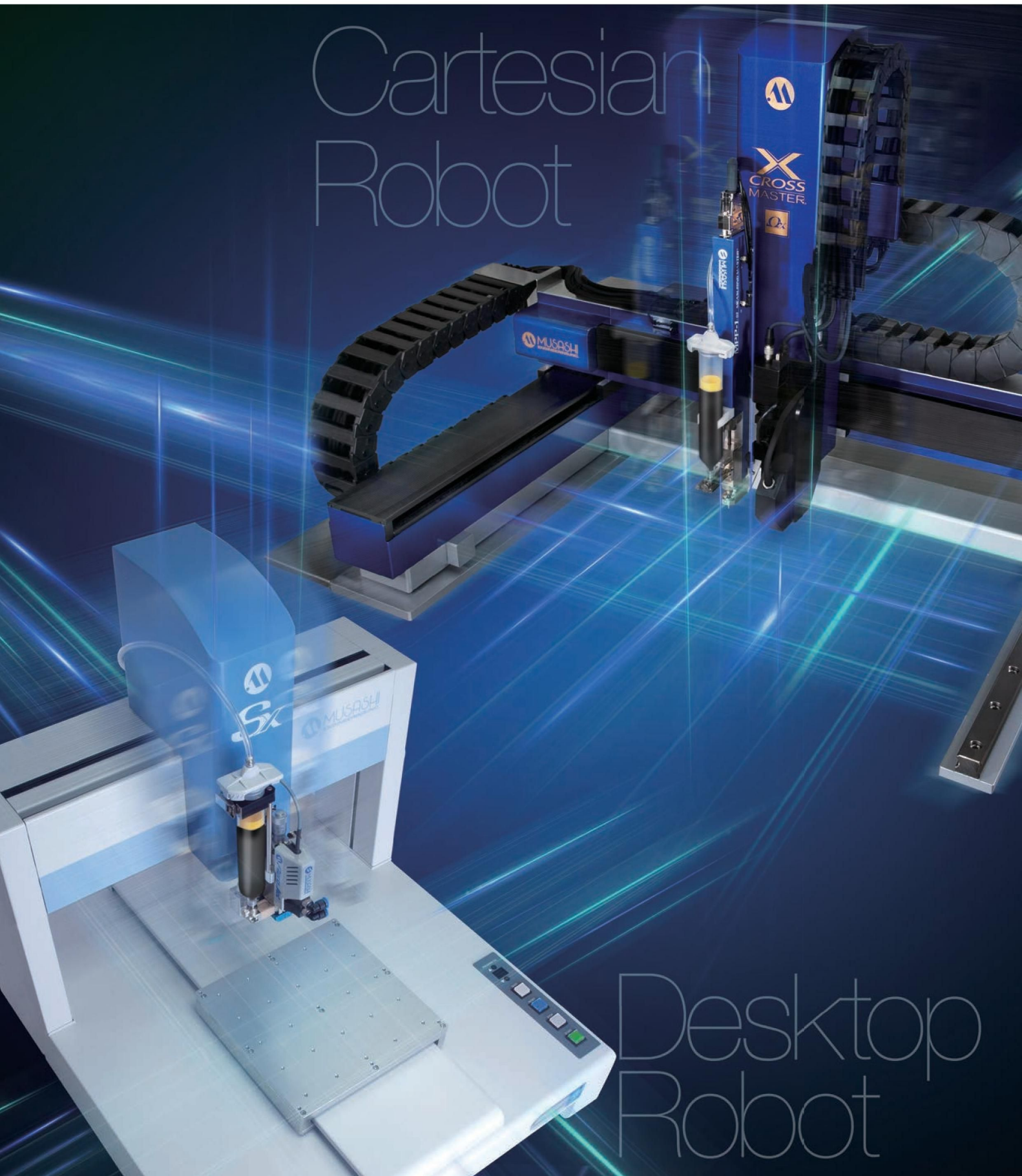

Cartesian
Robot

Desktop
Robot

SHOTmini™/SHOTMASTER™ SX series

MUSASHI's general-purpose desktop robot, the global de facto standard.



SHOTmini™/SHOTMASTER™ SX series Line up



Specifications

Item name	SHOTmini100SX		SHOTmini 200SX		SHOTMASTER 300SX		SHOTMASTER 400SX		SHOTMASTER 500SX		
Model	SM100SX-3A-SS	SM200SX-3A-SS	SM200SX-3A-Z-SS	SM200SX-4A-SS	SM300SX-3A-SS	SM300SX-4A-SS	SM400SX-3A-SS	SM400SX-4A-SS	SM500SX-3A-SS	SM500SX-4A-SS	
No. of controlled axes	3-axis		4-axis		3-axis		4-axis		4-axis		
Travel ranges	X-axis, Y-axis	100mm		200mm		300mm		400mm		500mm	
	Z-axis	50mm						80mm			
	W-axis	-		±360°		-		±360°		-	
Setting range of PTP operation speed (*1)	X-axis, Y-axis	1 to 800 mm/s									
	Z-axis	1 to 350 mm/s		1 to 250 mm/s		-		1 to 400 mm/s		-	
	W-axis	-		1 to 900°/s		-		1 to 900°/s		-	
Setting range of interpolation operation speed (*1)	X-axis, Y-axis	0.1 to 800 mm/s									
	Z-axis	0.1 to 350 mm/s		0.1 to 250 mm/s		-		0.1 to 400 mm/s		-	
	W-axis	-		0.1 to 900°/s		-		0.1 to 900°/s		-	
Repetitive positioning accuracy (*2)	X-axis, Y-axis	±0.01mm									
	Z-axis	±0.01mm									
	W-axis	-		±0.01°		-		±0.01°		-	
Loading capacity (*3)	Y-axis	8kg				15kg					
	Z-axis	2kg		3.5kg		2.5kg		7kg		6kg	
Rated voltage and frequency	AC100-240V 50/60Hz										
Power consumption	100W		120W		200W		220W		200W		
External dimensions (*4) (excluding protrusions)	W	202mm		302mm		510mm		610mm		710mm	
	D	290mm		301mm		570mm		670mm		770mm	
	H	440mm		455mm		555mm		590mm		690mm	
Weight	11kg		13.3kg		14.5kg		15.5kg		37kg		
		40kg		55kg		58kg		66kg		69kg	

SHOTmini™/SHOTMASTER™ SX&OX series Common specifications

Common specifications

Control method (*5)	PTP control and interpolation control	
Interpolation function	3-D line, 3-D circular arc/circle, 3-D elliptic arc/ellipse, spline	
Number of input/output signal points	General-purpose input	26 points
	General-purpose output	26 points
Program entry method	Teaching pendant, PC	
Program display language	Japanese, English, Chinese	
Program capacity (*6)	40000 steps (999 channels)	
Program storage system	Internal	Internal memory
	External	Backup on PC with dispensing pattern editing software
Program editing software	MuCAD V (option)	

- *1 These values vary depending on the operations, weight and center of gravity of the loaded object, and other factors.
- *2 This value is measured by the method specified by Musashi (measurement method complies with JIS).
- *3 When options are not installed. The value varies with setting speed, setting acceleration/deceleration time, and operations.
- *4 W and D are the dimensions of the lower section of the case.
- *5 PTP control: Control to move each specified axis to the end coordinates at each speed. Interpolation control: Control to move each specified axis to the end coordinates at the total interpolated speed.
- *6 Main routine: 1 to 99 CH, sub routine: 100 to 999 CH
- * OX series has no (motor) step-out specifications.

Outside drawings

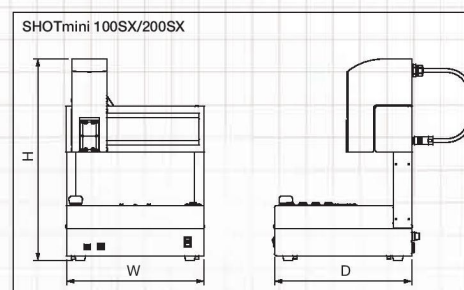

Angled approach

4-axis specification robot



Work rotation specification (custom)



Easier maintenance

Nozzle adjuster

- Automated nozzle position offset adjustment after syringe replacement
- Significant reduction in downtime
- Nozzle position can be adjusted while dispensing program is running



SHOTmini™/SHOTMASTER™ QX series

A fusion of dispensing technologies:
“High Precision” and “High Rigidity”

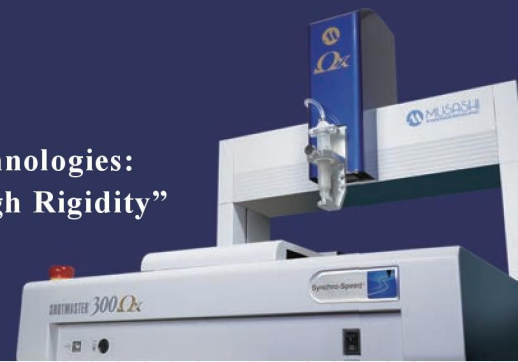

SHOTmini™/SHOTMASTER™ QX series Line up



SHOTmini 200QX



SHOTMASTER 300QX



SHOTMASTER 400QX



SHOTMASTER 500QX

Specifications

Item name	SHOTmini 200QX		SHOTMASTER 300QX		SHOTMASTER 400QX		SHOTMASTER 500QX		
Model	SM200OMEGAX-3A-SS	SM200OMEGAX-4A-SS	SM300OMEGAX-3A-SS	SM300OMEGAX-4A-SS	SM400OMEGAX-3A-SS	SM400OMEGAX-4A-SS	SM500OMEGAX-3A-SS	M500OMEGAX-4A-SS	
No. of controlled axes	3-axis		3-axis		3-axis		3-axis		
Travel ranges	X-axis, Y-axis	200mm		300mm		400mm		500mm	
	Z-axis	80mm							
	W-axis	-	±360°	-	±360°	-	±360°	-	±360°
Setting range of PTP operation speed (*1)	X-axis, Y-axis	1 to 500mm/s							
	Z-axis	1 to 400mm/s							
	W-axis	-	1 to 900°/s	-	1 to 900°/s	-	1 to 900°/s	-	1 to 900°/s
Setting range of interpolation operation speed (*1)	X-axis, Y-axis	0.1 to 500mm/s							
	Z-axis	0.1 to 400mm/s							
	W-axis	-	0.1 to 900°/s	-	0.1 to 900°/s	-	0.1 to 900°/s	-	0.1 to 900°/s
Repetitive positioning accuracy (*2)	X-axis, Y-axis	±0.005mm							
	Z-axis	±0.005mm							
	W-axis	-	±0.01°	-	±0.01°	-	±0.01°	-	±0.01°
Loading capacity (*3)	Y-axis	20kg							
	Z-axis	15kg	12kg	15kg	12kg	15kg	12kg	15kg	12kg
Rated voltage and frequency	AC100-240V 50/60Hz								
Power consumption	130W	150W	130W	150W	180W	200W	180W	200W	
External dimensions (*4) (excluding protrusions)	W	380mm		510mm		610mm		710mm	
	D	460mm		570mm		670mm		770mm	
	H	590mm	690mm	590mm	690mm	590mm	690mm	590mm	690mm
Weight	30kg	33kg	40kg	43kg	55kg	58kg	66kg	69kg	

Measurement unit (mm)

SHOTmini 200QX

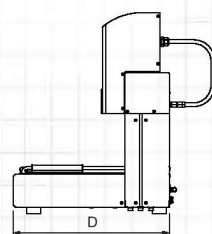
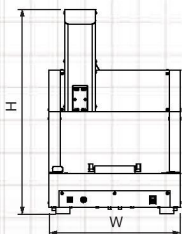

SHOTMASTER 300SX/400SX/500SX/300QX/400QX/500QX

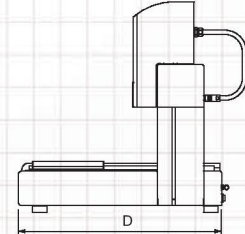
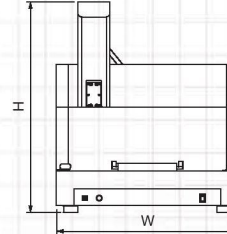

SHOTmini™/SHOTMASTER™
SX&QX
Model Identification

Type	X, Y stroke	Series	No. of Axes	Extension	SS function
SM 200	100:100×100mm 200:200×200mm 300:300×300mm 400:400×400mm 500:500×500mm	SX OMEGAX	3A 3A:3-axis 3A-Z:3-axis, strengthened Z-axis 4A:4-axis	EXT100 None:Standard height EXT50: +50mm EXT100: +100mm	SS None SS

*SS: Synchro Speed™ function PTP *QX series are equipped with SS function as standard
*100 x 100 mm is available for SX only *3A-Z is available for 200SX only *100SX is not available with 4A or extension



MUSASHI's dispensing motion unit is capable of being mounted on automatic units.



CROSSMASTER™ SX series Line up

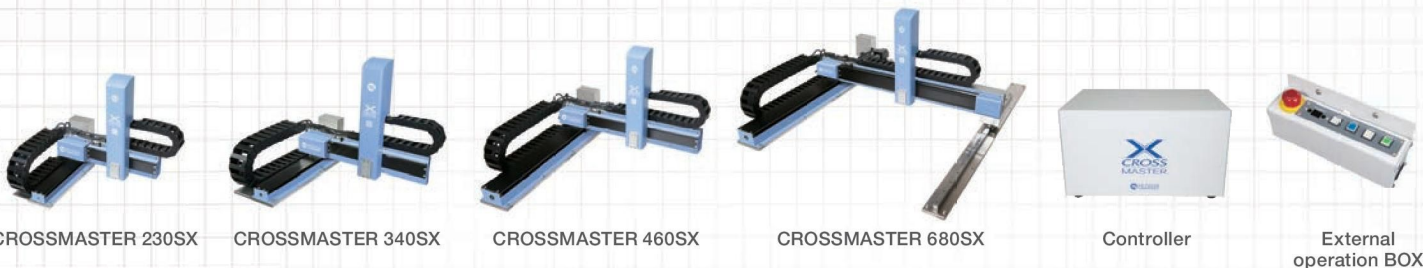

■ Specifications

Item name	CROSSMASTER 230SX	CROSSMASTER 340SX	CROSSMASTER 460SX	CROSSMASTER 680SX
Model	XM230SX-3A-L-SS XM230SX-3A-R-SS	XM340SX-3A-L-SS XM340SX-3A-R-SS	XM460SX-3A-L-SS XM460SX-3A-R-SS	XM680SX-3A-L-SS XM680SX-3A-R-SS
No. of controlled axes	3-axis			
Travel ranges	X-axis	200mm	300mm	400mm
	Y-axis	300mm	400mm	600mm
	Z-axis	150mm		
Setting range of PTP operation speed (*1)	X-axis	1 to 500mm/s		1 to 470mm/s
	Y-axis	1 to 500mm/s		1 to 1000mm/s
	Z-axis	1 to 300mm/s		
Setting range of interpolation operation speed (*1)	X-axis	0.1 to 500mm/s		0.1 to 470mm/s
	Y-axis	0.1 to 500mm/s		0.1 to 999.9mm/s
	Z-axis	0.1 to 300mm/s		
Repetitive positioning accuracy (*2)	X-axis	±0.01mm		
	Y-axis	±0.01mm		
	Z-axis	±0.01mm		
Loading capacity (*3)	2.5kg			
Rated voltage and frequency	Single phase, AC200-240 V 50/60 Hz			
Power consumption	200W		300W	
External dimensions (excluding protrusions)	W	565mm	635.5mm	760mm
	D	565mm	651mm	923mm
	H	470mm		490mm
Weight	25.5kg	28.5kg	44.5kg	67.5kg

CROSSMASTER™ SX&QX series Common specifications

■ Common specifications

Control method (*4)	PTP control and interpolation control	
Interpolation function	3-D line, 3-D circular arc/circle, 3-D elliptical arc/ellipse, spline	
Number of input/output signal points	General-purpose input	20 points
	General-purpose output	23 points
Program display language	Teaching pendant, PC	
Program entry method	Japanese, English, Chinese	
Program capacity (*5)	40000 steps (999 channels)	
Program storage system	Internal	Internal memory
	External	Backup on PC with dispensing pattern editing software
Program editing software	MuCAD V (option)	
Controller external dimensions (excluding protrusions)	W450×D340×H265 mm	
Weight of dispense controller	18kg	

- *1 These values vary depending on the operations, weight and center of gravity of the loaded object, and other factors.
 - *2 This value is measured by the method specified by Musashi (measurement method complies with JIS).
 - *3 When options are not installed. The value varies with setting speed, setting acceleration/deceleration time, and operations.
 - *4 PTP control: Control to move each specified axis to the end coordinates at each speed. Interpolation control: Control to move each specified axis to the end coordinates at the total interpolated speed.
 - *5 Main routine: 1 to 99 CH, sub routine: 100 to 999 CH
- *The XM460SX series, XM680SX series and XMQX series correspond to industrial robots.
*All models have no (motor) step-out specifications.

■ Outside drawings

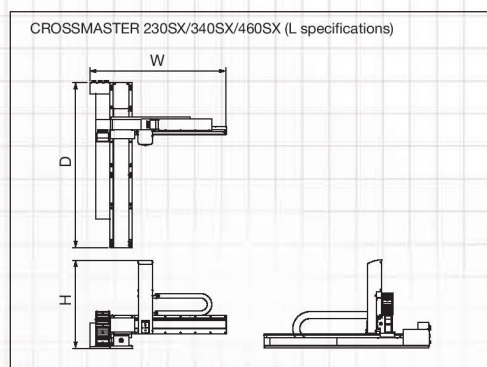

Coordinated with dispenser

Synchro Speed™ function PAT.P

Maintains a fixed line width, regardless of robot speed. Achieves high-quality dispensing automatically, without the need for any complex adjustments.



Right-angle dispensing



Fully enhanced operability

Teaching pendant

- Large, high-visibility screen with backlight
- 2-screen display makes programming easy
- Equipped with interactive user-friendly interface function
- Stopwatch function
- Dispensing condition switching function



- Data transfer function between robots
- Available in Japanese, English, and Chinese





CROSSMASTER™ ΩX series Line up



■ Specifications

Item name	CROSSMASTER 330ΩX		CROSSMASTER 440ΩX		CROSSMASTER 560ΩX		CROSSMASTER 780ΩX		
Model	XM330OMEGAX-3A-L-SS XM330OMEGAX-3A-R-SS	XM330OMEGAX-4A-L-SS XM330OMEGAX-4A-R-SS	XM440OMEGAX-3A-L-SS XM440OMEGAX-3A-R-SS	XM440OMEGAX-4A-L-SS XM440OMEGAX-4A-R-SS	XM560OMEGAX-3A-L-SS XM560OMEGAX-3A-R-SS	XM560OMEGAX-4A-L-SS XM560OMEGAX-4A-R-SS	XM780OMEGAX-3A-L-SS XM780OMEGAX-3A-R-SS	XM780OMEGAX-4A-L-SS XM780OMEGAX-4A-R-SS	
No. of controlled axes	3-axis		4-axis		3-axis		4-axis		
Travel ranges	X-axis, Y-axis	300mm×300mm		400mm×400mm		500mm×600mm		700mm×800mm	
	Z-axis	150mm							
	W-axis	-	±360°	-	±360°	-	±360°	-	±360°
Setting range of PTP operation speed (*1)	X-axis, Y-axis	1 to 500mm/s							
	Z-axis	1 to 400mm/s							
	W-axis	-	1 to 900°/s	-	1 to 900°/s	-	1 to 900°/s	-	1 to 900°/s
Setting range of interpolation operation speed (*1)	X-axis, Y-axis	0.1 to 500mm/s							
	Z-axis	0.1 to 400mm/s							
	W-axis	-	0.1 to 900°/s	-	0.1 to 900°/s	-	0.1 to 900°/s	-	0.1 to 900°/s
Repetitive positioning accuracy (*2)	X-axis, Y-axis	±0.005mm							
	Z-axis	±0.005mm							
	W-axis	-	±0.01°	-	±0.01°	-	±0.01°	-	±0.01°
Loading capacity (*3)	10kg	7kg	10kg	7kg	10kg	7kg	10kg	7kg	
Rated voltage and frequency	Single phase, AC200-240 V 50/60 Hz								
Power consumption	300W	320W	300W	320W	300W	320W	300W	320W	
External dimensions (*4) (excluding protrusions)	W	831mm		931mm		1031mm		1239mm	
	D	671mm		771mm		971mm		1171mm	
	H	630mm							
Weight	80kg	83kg	91kg	94kg	120kg	123kg	143kg	146kg	

Measurement unit (mm)

CROSSMASTER 680SX (L specifications)

CROSSMASTER ΩX series (L specifications)

Controller

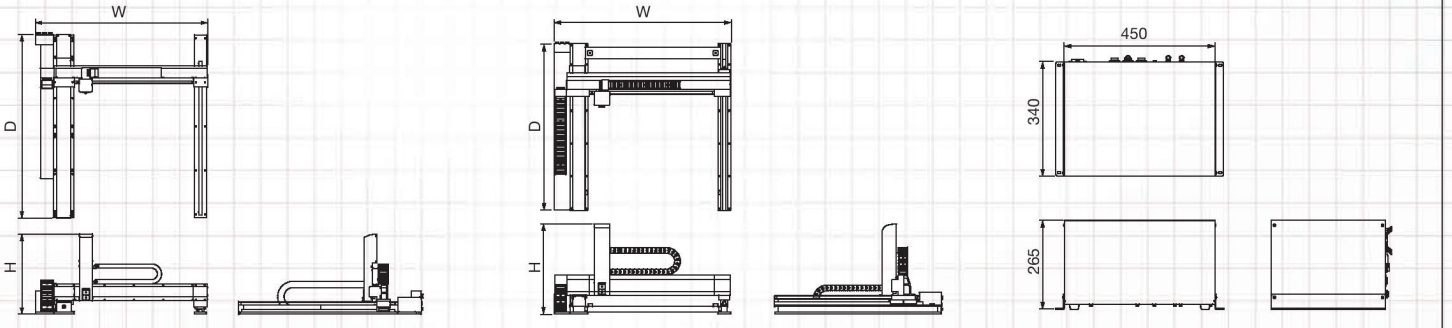

CROSSMASTER™ SX&ΩX Model Identification

Type	X, Y stroke	Series	No. of Axes	X-axis origin position	SS function
XM 330		OMEGAX	3A	L	SS
	230:200×300mm 340:300×400mm	SX	3A:3-axis 4A:4-axis	L:left R:right	None SS
	330:300×300mm 440:400×400mm		OMEGAX		

*SS: Synchro Speed™ function PAT.F
*ΩX series are equipped with SS function as standard *4A is available for ΩX only

IMAGE MASTER™ 350PC Smart

Introducing essential units and new functions for micro-dispensing and reliable production.



Full 3D alignment and tracing function

The 3D alignment and tracing functions enable “tracing (Z correction)” that provides XYθ correction to suit tilted or deformed pallets or workpieces, and maintains a constant clearance with warping or

distortion. This ensures more reliable dispensing. Now the dispensing track can be corrected to suit fluctuations in the shape of the workpiece.

■ Z correction

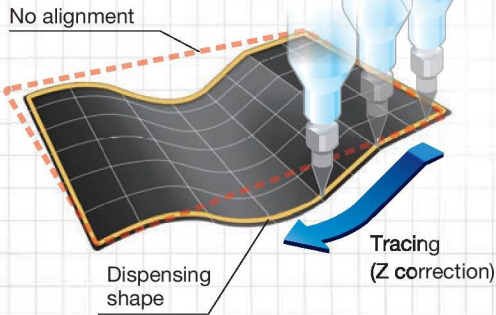

■ XYθ correction

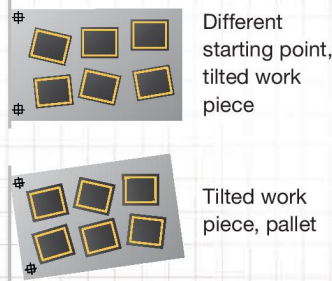

■ Dispensing track correction NEW

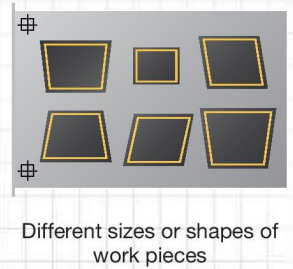

Camera teaching function

Align camera with dispensing position

Register coordinates

Program completed

Saving program creation time

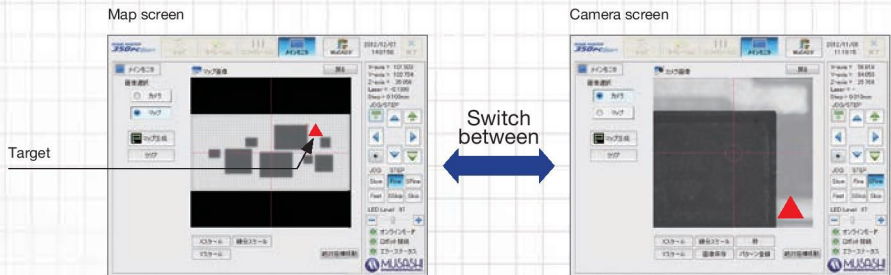

Reduced cycle time and greater yield

Easy liquid material changes and automatic correction

Syringe set-up function

Nozzle tip misalignment after changing liquid material can result in impact with work pieces or faulty dispensing.

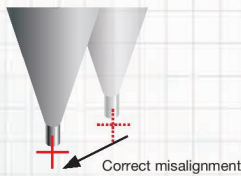

Tools required for reliable dispensing

Accessories unit

- Nozzle cleaning
- Test shot stage
- Nozzle touch sensor



Designed to handle various work shapes

Image processing and positioning recognition

- Pattern matching
- Center of gravity detection
- Edge detection NEW

Suitable for devices with irregular corner cuts

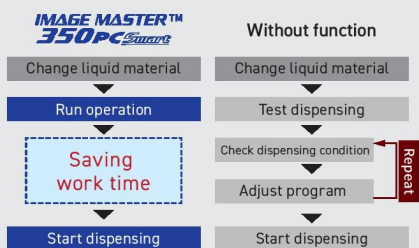
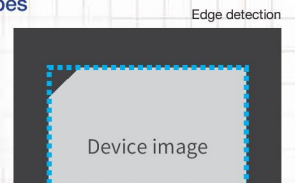

Unique operation function to easily correct misaligned nozzles

- Nozzle offset function
- Z-axis zero-point function

Production management

- Production log function
- Flexible start function
- Process monitoring function
- Recipe import/export function

Inspection

- Dimensions measurement function
- Image map creation function
- Dispensing track tracing function
- Quick dispensed area verification function

Outside drawings

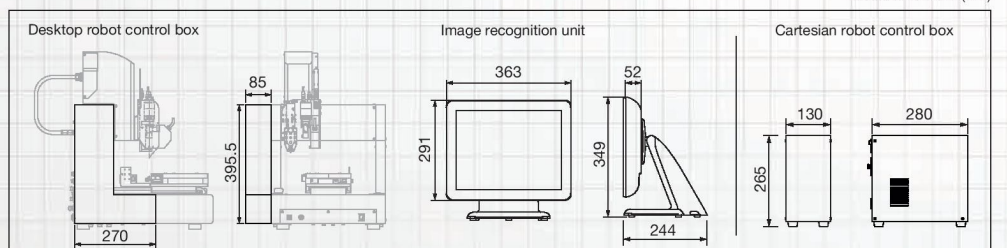

Measurement unit (mm)

MuCAD V™

Complex dispensing operations can now be programmed quickly and intuitively.



Powered with the leading dispensing know-how!

- Saving editing time.
- Intuitive drawing of dispensing patterns.
- Edit dispensing patterns easily, even by beginners.

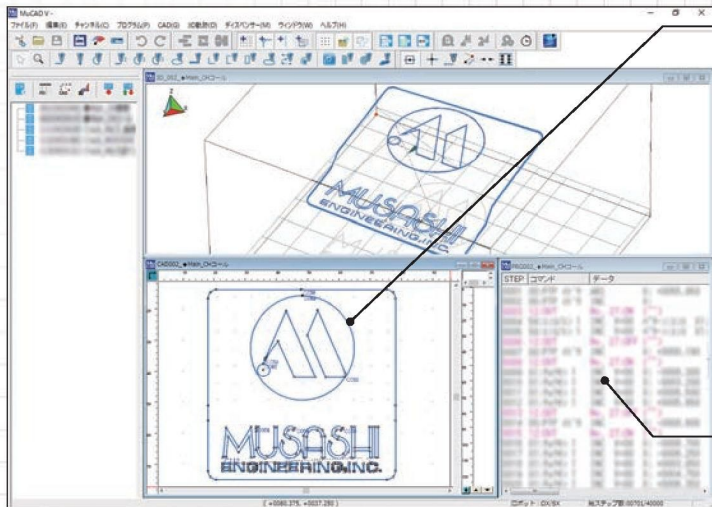

Entry by drawing

Use the mouse to create the "drawing" program to be dispensed

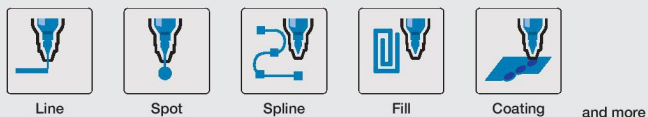

Useful functions

Generates multiple zigzag array program

Works straight away with various work layouts. Includes "copy/rotate/flip" function for dispensing programs.

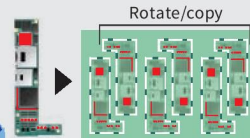

Linked

Entry by command

Create accurate programs by entering values

Useful functions

Pattern generator function

Configure any device layout on wafers. Helps to reduce programming time significantly.

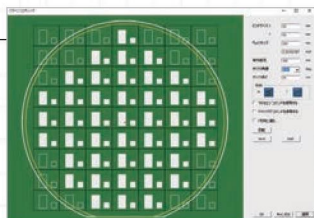

Automatic program creation

Automatically create dispensing programs from Gerber data.

- Can also be created automatically from sources other Gerber data
- DXF data
- Coordinate data



Cut out dispensing prohibited areas

Includes cut intermediate dispense area function to separate dispensing into dispense areas and prohibited areas.

*For conformal coating

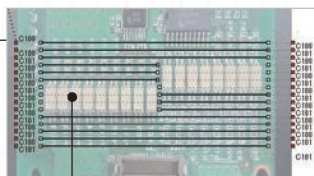

Cut intermediate area

Drawing by hand function

Programs can be created intuitively by hand (free line drawings).

Mu-Sketch



System requirements









OS	Windows® 10, Windows® 8.1, Windows® 7
CPU	Pentium® 4 2 GHz equivalent or faster
Memory	512 MB or more (1 GB or more recommended)
Display	XGA (1024x768) or higher resolution
Hard disk	100 MB or more available space
USB port	USB port x1 (SHOTMASTER QX/SX series, CROSSMASTER QX/SX series)
Serial port	Serial port x1 (SHOTMASTER DS/DSS series, other older models) Separate serial port x1/unit required when connecting the dispenser. USB serial converter can be used.
Applicable robots	SHOTMASTER QX/SX series, SHOTMASTER DS/DSS series, CROSSMASTER QX/SX series, also compatible with other older models

* This software is protected by the Copyright Act, and may not be copied or modified without prior consent of Musashi Engineering, Inc.
* Microsoft Windows is a registered trademark of Microsoft Corporation.

Connection image



Robot list

	Speed type	High-precision, high-rigidity type
Desktop robot <div style="border: 1px solid blue; padding: 5px; margin-top: 10px;"> Semi automatic production Research/ development </div>	SHOTmini™/SHOTMASTER™ SX series Stroke 100/200/300/400/500 PTP operating speed Up to 800mm/s  	SHOTmini™/SHOTMASTER™ OX series Stroke 200/300/400/500 Repetitive positioning accuracy ±0.005mm  
Cartesian Robot <div style="border: 1px solid red; padding: 5px; margin-top: 10px;"> Large workpiece mounted on automatic unit </div>	X-CROSS MASTER™ S series Stroke 230/340/460/680 One-sided type LR specifications  	X-CROSS MASTER™ A series Stroke 330/440/560/780 Loading capacity Up to 10Kg  

Fully automatic dispensing machine

Fully automatic high-end dispensing machine

DISPENS MASTER™ FAD™ 5100S

Underfill material fully automatic dispensing machine

Applications

- Underfill dispensing
- Dispensing dam agent
- Part sealant, reinforcement
- Micro-deposit spot dispensing



Temporary bonding material high-speed JET dispensing machine

DISPENS MASTER™ FAD™ 2500SA

For "superb reliability" with "any dispensing volume or shape."

Applications

- Temporary bonding material (included in SMT lines)



 **Safety precaution**
 Make sure to read the instruction manual before you use the unit, for your safety.

* We reserve the right to change the specifications without notice.
 * All copyrights are retained by MUSASHI ENGINEERING. Reprinting, reproducing, and/or transmitting as electronic data in whole or in part these material without prior written permission is strictly prohibited.

MUSASHI ENGINEERING, INC. is certified and registered according to ISO14001 ENVIRONMENTAL MANAGEMENT.



Váš dodavatel Musashi pro Česko a Slovensko



AMTECH, spol. s r.o.

Tel.: +420 541 225 215

E-mail: davkovani@amtech.cz

Web: www.amtech-dispensing.cz

